

NOTES:

REF. BUL. 100 & T-103 FOR THE FOLLOWING:

b - ACCURACY CODE

e - POINTER TYPE

f - DIAL TRIM

gg - PRESSURE RANGE CODE (T-103)

h - CASE COLOR

i - FITTING LOCATION

j - FITTING TYPE

k - ADDITIONAL OPTIONS

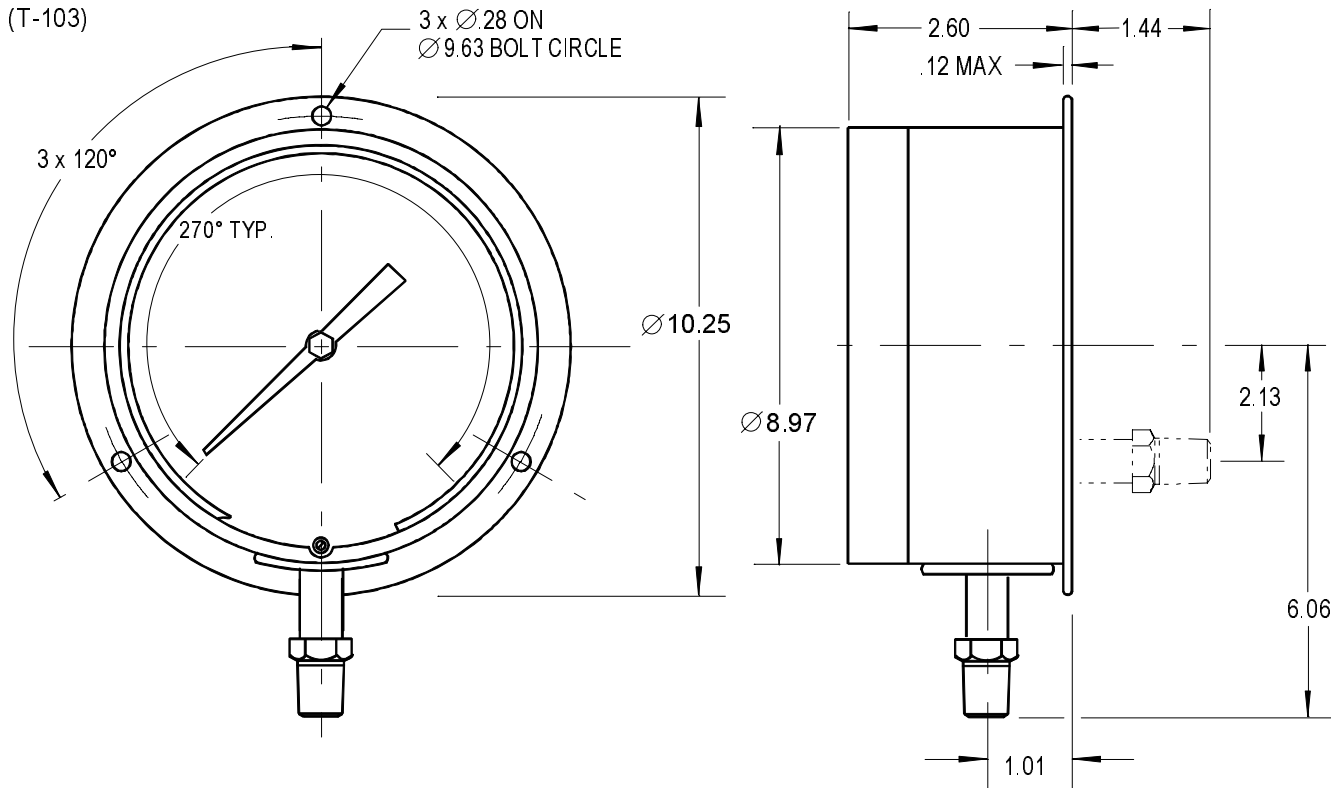

REVISIONS			
REV	DESCRIPTION	DATE	APPROVED

UNLESS OTHERWISE SPECIFIED DIMENSIONS ARE IN INCHES	
ANGULAR	$\pm 1^\circ$
LINEAR	.XX $\pm .030$
	.XXX $\pm .015$
FRACTIONAL	$\pm 1/16$
DIAMETERS ON SAME C/L RUNOUT WITHIN <u>.016</u> FIR	
<input checked="" type="checkbox"/> SURFACE ROUGHNESS USAS B46.1	

MATERIAL:	ALUMINUM
FINISH:	POWDER COAT

CONTRACT NO.		
PREP BY	PAL	DATE 6/11/2007
CHECK		
PROJ ENGR		
USED ON: INDUSTRIAL GAUGES		
FILE NAME: 1b8Refgghij-Z		

PERMA-CAL INDUSTRIES, INC.			
GAUGE, 8 1/2" ALUMINUM REAR FLANGE			
SIZE A	CODE IDENT NO. 59018	DRAWING NO. 1b8Refgghij-Zk	REV N/C
SCALE NONE	WEIGHT	SHEET 1	OF 1